



nosstec

BENDING ROLL MACHINE 8835

The 8835 is a bending roll machine for the production of small radius louvres and reflectors to meet the demands of the latest small diameter light tubes.

The machine is designed with three independent bottom rolls to reduce production time to a minimum. All rolls run in adjustable support bearings to permit easy roll adjustment for materials of different hardness and thickness. The top roll crowning is carried out by means of a crossbeam, which tilts to make room for the bent part. All rolls are hardened and chromium-plated with polished surfaces to avoid marking. All four rolls are driven in order to avoid scratches on easily damaged sheets from slipping rolls. The control system allows programming of constant radius parts as well as parabolic shapes.

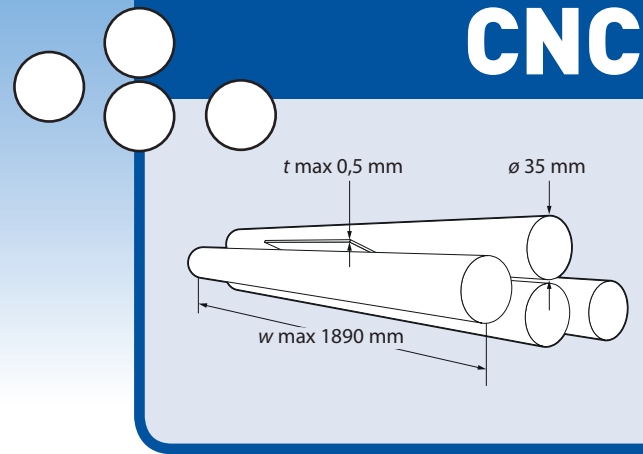

- ▶ CNC-control with the capacity to store 200 programs in internal memory and nearly unlimited by attaching an external USB flash drive
- ▶ Pre-bending and final bending in one cycle
- ▶ All four rolls are driven
- ▶ Crowned rolls
- ▶ Programmable axis
- ▶ Designed for highest accuracy
- ▶ Front-roll or back-roll position can be programmed to flexibly vary bend diameter
- ▶ Adjustable crowning of the rolls
- ▶ Program backup through external computer or attached USB flash drive

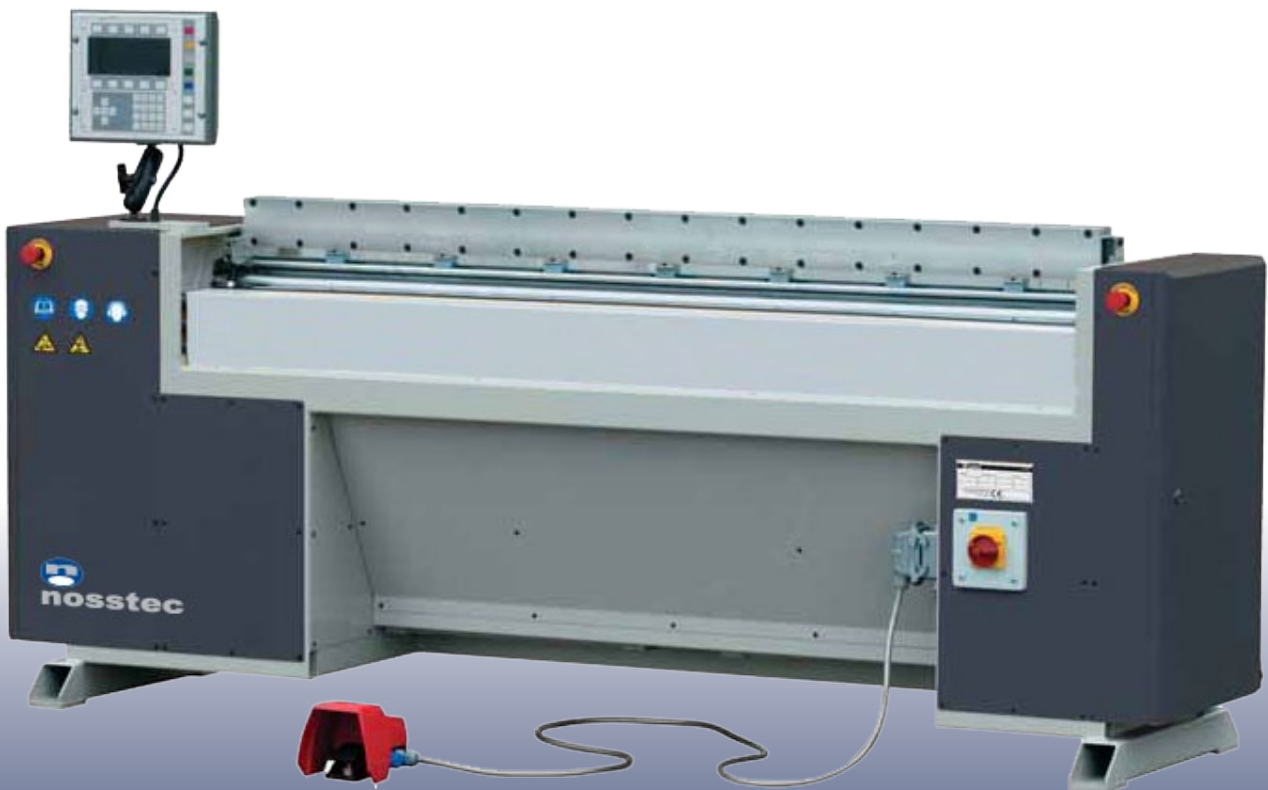

Nosstec AB, Kristineholmsvägen 12, 441 39 Alingsås, SWEDEN

Tel: +46 (0)512 - 298 85 • Fax: +46 (0)512 - 298 89 • E-mail: info@nosstec.se • Web: www.nosstec.se

For copyright reasons all reproduction and copying of the texts, photos, tables and illustrations is prohibited without written permission from Nosstec AB.

Simple to use control panel

The programming of the machine is facilitated by different menus available on the screen. In order to further simplify the programming, the control buttons are of multi-function type, whose functions are automatically changed when changing menus. The CNC has an internal storage capacity of 200 programs or near unlimited with an external USB flash drive.

The program consists of sections, where each section is provided with a bending value. This enables easy and quick programming of the machine for different bending operations. The CNC system can operate with interpolation, where the rolls are adjusted simultaneously with the feeding operation.

Optional equipment

- ▶ Stacking tables
- ▶ Infeed automation
- ▶ Outfeed automation
- ▶ Online feeding unit 1700

Online feeding unit 1700

The unit consists of a driven roller way and a pneumatic pushing device for pushing the blanks (Alu-sheets) into the roller. The concept makes it possible to integrate a punching line with 8835/8344. Unit 1700 is equipped with a slave computer connected to the control system of the bending roll. The unit can be installed or removed in about 5 min.

Art.no.	8835	-1805
Capacity		18/05
Working length (<i>w</i>)	mm	1890
Max. sheet thickness steel (250 N/mm ²) (<i>t</i>)	mm	0,5
Diameter of rolls (\emptyset)	mm	35
Motor output	kW	0,75
Max. working speed	m/min	9,1
Net. weight	kg	900

Product application examples.

